



DENALI Plow Mount MA11746 CanAm Maverick

Thank you for purchasing our DENALI plow mount. You now own a premium custom plow mount to allow you to use your plow with your SxS. Please note the following instructions and heed all warnings.

- Your UTV/SxS and/or plow system can cause death or injury, please use caution and common sense when operating your unit.
- Read your Plow Operator Manual, your Winch Operator Manual, and all warning labels before operating your UTV/SxS.
- Operate your UTV/SxS at a walking speed with the blade installed. Do not exceed 5 mph (8 km/h), even with the blade up.
- Do not operate the UTV/SxS on slopes greater than 10 degrees with the plow installed.
- Always lower the plow to the down position before leaving your UTV/SxS unattended.

SEVERE INJURY OR DEATH MAY RESULT IF YOU ARE NEGLIGENT.

Please verify that all hardware and parts are included in your package.

Kit Contents:

Item Number	Quantity	Part Numer
1	1	MA11746 Plow Mount
2	1	Rear Support Bracket
3	2	Side Support Brackets
4	4	5/16" x 2 1/2" Serrated Flange Bolt
5	4	3/8" x 1 1/4" Serrated Flange Bolt
6	2	3/8 x 2" ID U-bolt
7	4	5/16" Serrated Flange Nuts
8	8	3/8" Serrated Flange Nuts

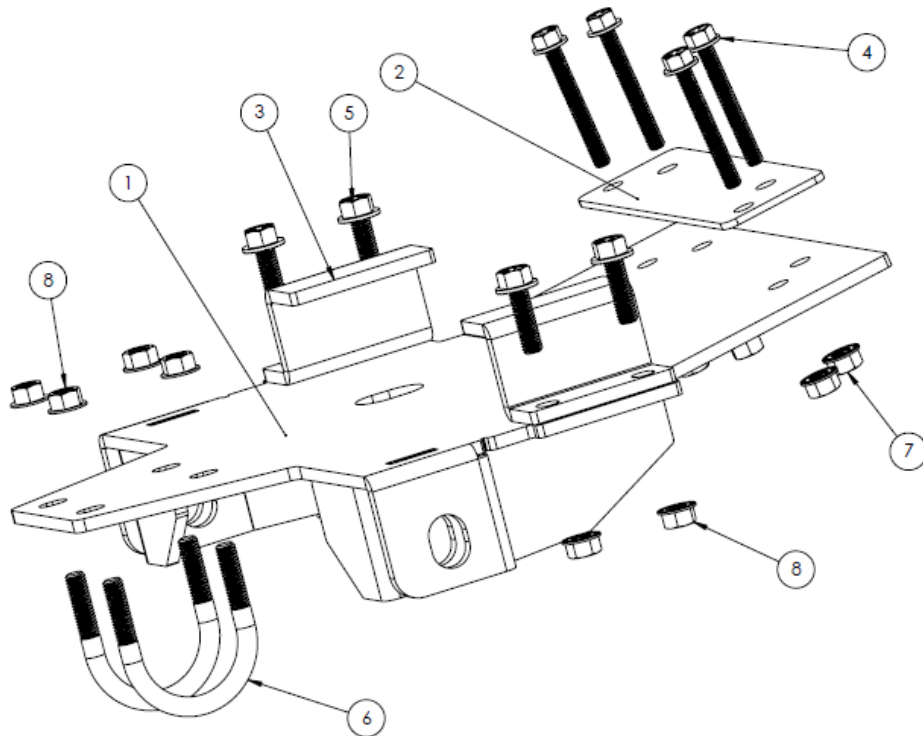

Figure 1



CanAm Maverick Installation Instructions

1. Remove the two front triangle shaped plastic guards as shown in the picture below



2. Remove the next four retainer bolts that hold the plastic underbody as shown in the picture below.

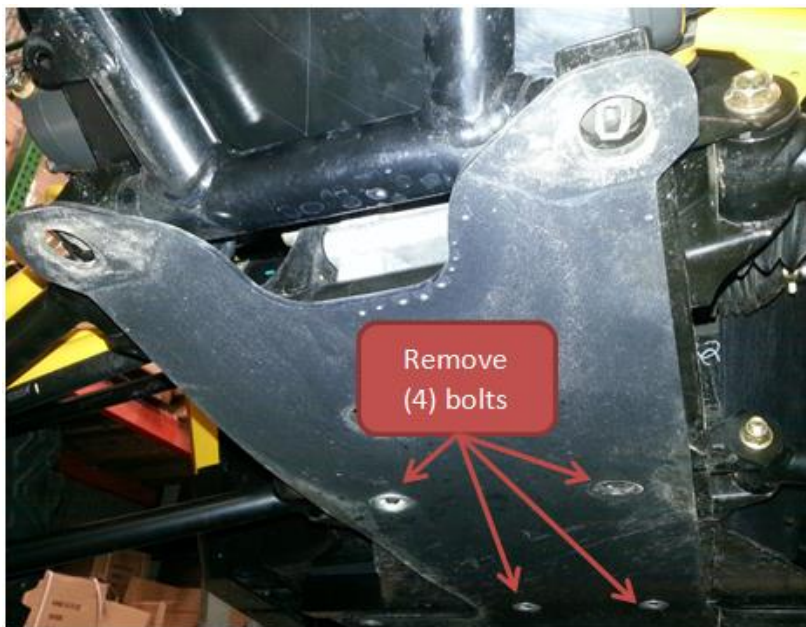



3. Remove the (2) 1/4" U-Nuts that are attached to the frame just behind the differential. The U-Nuts are most easily removed using a small flat head screw driver to lift up the retainer clip. These will no longer be needed. With the U-nuts removed, you can replace the rear most M10 bolts that were taken off in Step 2.



4. From the top side of the underbody, behind the differential you will find four holes. Place the Rear Support Bracket on top of the holes and drop (2) of the 5/16" x 2 1/2" Serrated Flange bolts down from the top as shown below. **Note:** only use the front most bolt holes at this time.





5. Lift the plow mount up to the bottom of the Maverick such that the two bolts stated earlier align with the bolt holes in the mount. Use (2) of the 5/16" Serrated Flange Nuts to secure the rear bolts and hold the mount up to the frame.

Note: the plastic underbody will be sandwiched between the frame & the mount

6. Once the mount is held in place you will need a 5/16" drill bit to clearance (2) holes in the plastic underbody. You will use the mount as a guide to drill the holes. Clearance out the rear most holes.
7. Locate the (2) 3/8" U-bolts in your hardware kit. Slide the U-bolts sideways until they are positioned over the front cross support tubing. Allow the two ends of the U-bolts to drop around the tubing.





- 8.** Raise up the front of the plow mount to the newly hung U-bolts. Secure each with the 3/8" Serrated Flange Nuts.
- 9.** Drop the remaining 5/16" x 2 1/2" Serrated Flange Bolts through the newly drilled holes in the rear of the mount. Secure with the Flange Nuts.
- 10.** Position the Side Support Brackets on either side of the mount and secure them with the remaining 3/8" Serrated Flange Bolts and Nuts. Verify all the bolts are secure.
- 11.** After your first plowing, verify that all the bolts are secure.